

## Single Sideband Transmitters.

There are two general methods of generating an SSB signal. The Filter method and the phasing method.

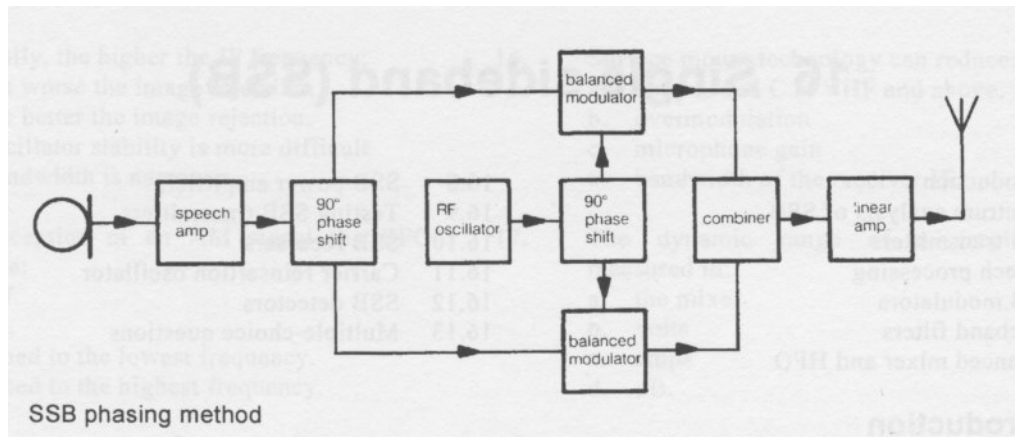

The above diagram shows a block diagram of SSB generator using the *phasing method*. This method is less popular due to the complexity of the circuits necessary and the difficulty in tuning the transmitter. It is achieved by placing the unwanted sideband in phase with the required sideband and, as the sidebands are mirror images of one another, one is effectively removed. A knowledge of the block diagram only is required. Some PLL phase splitting circuits are available that will maintain the required 90° phase shift over a wide range of frequencies.

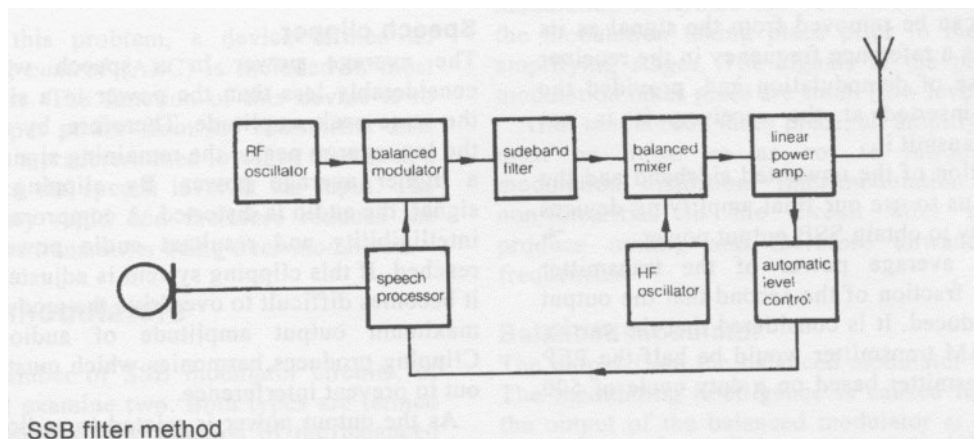

shows a block diagram of an SSB transmitter using the filter method. As the name implies it is a method of generating SSB by using a very selective filter to remove the unwanted sideband. This method is the one which is most popular in radio equipment today due to crystal filters being very selective, fairly efficient and relatively cheap.

Consider the function of each block in the SSB transmitter of the filter method type.

1. The RF oscillator produces an RF carrier.
2. The speech processor processes the audio in such a way as to produce the desired power output. This device contains audio amplifiers and other devices which will be discussed later in this chapter.
3. The balanced modulator combines the RF and the audio. The audio is superimposed on the amplitude of the carrier. This is carried out in such a way as to cause the carrier to be suppressed. The output of this stage is double sideband suppressed carrier (DSBSC). The carrier oscillator and the modulator section of the transmitter are sometimes collectively called an SSB exciter.

4. The filter causes the unwanted sideband to be removed.
5. The mixer and high frequency oscillator heterodyne the RF oscillator frequency up to the desired transmitted frequency. This is a frequency translation step that functions in a similar manner to the balanced modulator.
6. The linear amplifier provides the transmitted RF power.

The major difference between the SSB transmitter and the AM transmitters previously discussed is that the AM transmitters were all high-level modulated whereas this SSB transmitter is low-level modulated. The advantage of low-level modulation is that the power in the modulation circuit is small, therefore easily manipulated. The disadvantage is that all the stages after the modulator must be linear and therefore will operate class A or A/B push-pull. This is less efficient than the class C amplifier in AM transmitters. SSB transmitters are generally associated with linear amplifiers.

Most of the blocks of this transmitter have been previously covered in the section on AM transmitters. We shall only examine circuits of the blocks not previously covered.

## **Output power.**

The output power of an SSB transmitter is directly related to the audio power present at the microphone input. If the PTT switch is operated and there is no speech present, then there is no output power from the transmitter. In an AM transmitter, when the PTT switch is operated, carrier appears in the output.

Audio power during normal speaking conditions is present for about 50% of the time. The ratio of time that the transmitter is producing power compared to the time that it is off is termed duty cycle. An SSB transmitter that is modulated using speech has a duty cycle of 0.5 second or 500 milliseconds (ms); that is the speech is producing output power for 50 per cent of the time.

A linear power amplifier transmitting a signal with a duty cycle of 100 per cent, that is the signal is always on, can be driven with an SSB signal having a duty cycle of 500 ms and obtain approximately twice the output power without causing an overload to the power-amplifying devices.

The power output of an SSB transmitter is measured in peak envelope power (PEP). In simple terms this means that an AM transmitter, rated at 100 watts of carrier power, would be capable of passing 200 watts of PEP when operating SSB with a 50 per cent duty cycle.

*Peak envelope power (PEP)*

SSB transmitters have their output power rated in PEP instead of carrier power output, as with AM transmitters. To fully understand the output power advantage of an SSB, consider the power distribution of a 100% modulated AM signal of 100 watts.

The amplitude of each sideband is limited to one half of the carrier; therefore, the maximum power of a sideband will be one quarter of the modulated power. The power of a 100 watt carrier when modulated by a sine wave is 150 watts.

1. Power in the sidebands = 50 watts when 100% modulated.
2. Power in a sideband when 100% modulated = 25 watts.

The carrier can be removed from the signal as its only purpose is a reference frequency in the receiver for the purpose of demodulation and, provided the carrier is re-inserted at the receiver, it is not necessary to transmit it.

The elimination of the unwanted sideband and the carrier allows us to use our final amplifying devices more efficiently to obtain SSB output power.

PEP is the average power of the transmitter divided by the fraction of the second that the output is actually produced. It is considered that the carrier power of an AM transmitter would be half the PEP of an SSB transmitter based on a duty cycle of 500 ms.

The diagram below is a representation of a voice modulated signal showing peak and average of the RF envelope. The peak envelope power is the power present only at the peak of the wave, whereas the average is the true average of the wave.

It gives an indication of the effect on average output power after some speech processing.

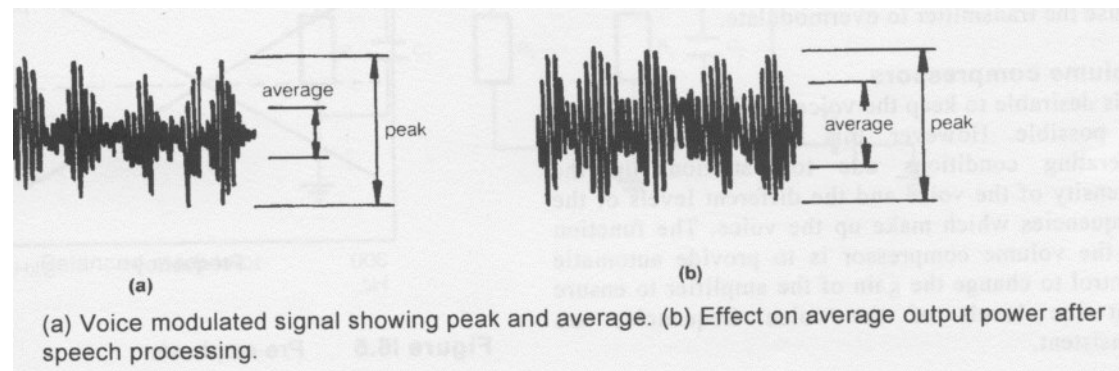

### Speech Processing.

As the average output power of an SSB transmitter is dependent on the level of the speech, it is important that the speech level be consistently high. To achieve this, a speech processor is used. The speech processor consists of the following circuits:

1. Speech Amplifier.
2. Volume compressor
3. Speech Clipper

### Speech amplifiers

The speech amplifiers provided in SSB transmitters are similar to the speech amplifiers previously covered. The gain of these amplifiers is controllable from an external control usually termed *microphone gain (mic gain)*. The microphone gain setting of an SSB transmitter is important, as too much gain can cause the transmitter to over modulate.

### Volume Compressors.

It is desirable to keep the voice level average as high as possible. However, this is difficult under all operating conditions due to variations in the intensity of the voice and the different levels of the frequencies which make up the voice. The function of the volume compressor is to provide automatic control to change the gain of the amplifier to ensure that the levels of the voice frequencies are constant.

### Speech Clipper.

The average power in a speech waveform is considerably less than the power in a sine wave of the same peak amplitude. Therefore, by clipping off the low energy peaks, the remaining signal will have a higher average power. By clipping the audio signal, the audio is distorted. A compromise between intelligibility and resultant audio power must be reached. If this clipping system is adjusted correctly, it becomes difficult to overdrive the modulator as the maximum output amplitude of audio is fixed. Clipping produces harmonics which must be filtered out to prevent interference.

As the output power is related to audio, an excess in audio can cause over-modulation and therefore interference to other frequencies. This interference is termed *splatter*.

### Pre-emphasis.

A further consideration of the speech processor used in SSB transmitters is the problem of the low voice frequencies having more power than the high frequencies. This can cause the low frequencies to over modulate, whereas the high frequencies will not. A frequency sensitive circuit may be included in the speech processor to ensure the power of all the voice frequencies are equal. In the transmitter, this circuit is termed *pre-emphasis*. Below is a graphical representation of this process.

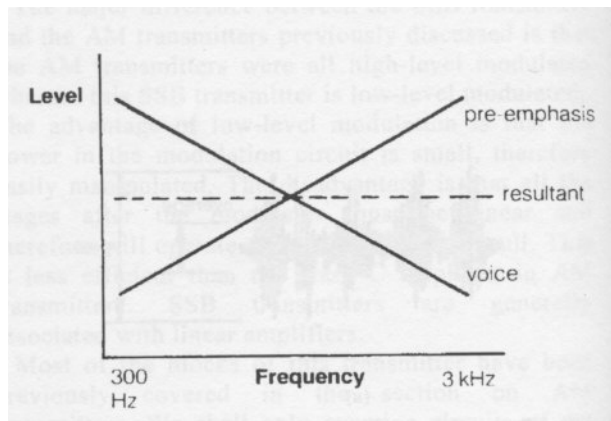

**Automatic Level Control.**

As the speech level fed into an SSB transmitter is related to the output power produced, it is possible for excessive speech level to cause the transmitter to over modulate. To overcome this problem, a device termed an automatic level control (ALC) is included in most SSB transmitters. The function of this device is to sample the output power from the transmitter and, when it reaches a predetermined level, to feed back a signal to reduce the speech level at the input. The feedback is very rapid and therefore reduces the possibility of the transmitter being over-modulated.

## **SSB Modulators.**

There are a number of SSB modulator circuits, of which we shall examine two. Both types are termed balanced modulators. The function of the balanced modulator is to produce an output with the carrier removed. There will be no output from the modulator until speech is present at the microphone input. When speech is applied to the modulator together with carrier, a mixing process takes place and the output will consist of the sum and difference as well as the original frequencies.

The required frequencies are selected by using frequency sensitive components.

This type of modulation is termed low-level modulation, due to the modulation taking place prior to the final RF amplifying stages. The signals at the point where modulation takes place are small (low level). After modulation takes place, all amplifying stages must be linear so as not to introduce intermodulation distortion. Inter-modulation occurs if non-linearities in the circuit after modulation produce mixing and therefore unwanted output frequencies.

## **Balanced Modulator**

The output from the balanced modulator is DSBSC. The modulating intelligence is caused to appear at the output of the balanced modulator at the rate or frequency of the RF carrier. **The balanced modulator suppresses the carrier but does not totally remove it. The carrier that appears in the output should be at least 40 dB lower than the signal in the output.** The RF carrier is about ten times larger than the modulating signal. This reduces speech distortion by causing the transistors to conduct because of carrier in preference to the speech signal.

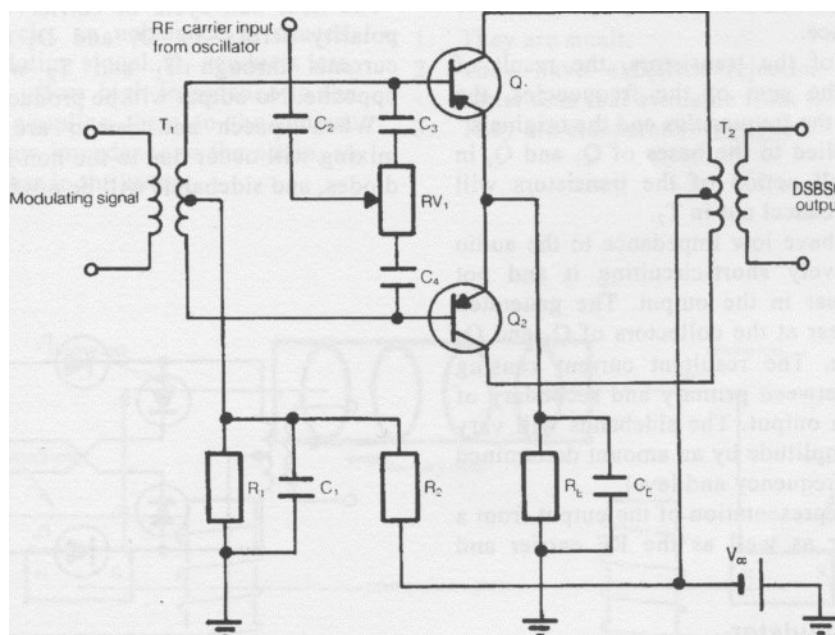

Balanced Modulator above.

The transistors are configured in a push-pull arrangement and have combination bias. The bias is obtained from the voltage divider  $R_1$  and  $R_2$  to the base of the transistors via the centre tap of  $T_1$ . An emitter resistor and bypass capacitor are shared between the two transistors  $R_E$  and  $C_E$ .

When carrier alone is applied to the circuit, i.e. PTT with no voice, it is applied equally to both the transistor bases, via the carrier balance adjustment potentiometer. The output currents from the collectors of the transistor are caused to flow through  $T_2$ . The currents flowing through  $T_2$  are equal, but in opposite directions, so their magnetic effects cancel one another out. Therefore, very little carrier



output occurs in the secondary of T<sub>2</sub>.

When carrier and voice are applied together, a mixing effect across the non-linear junction of the transistors takes place.

At the collectors of the transistors, the result of mixing produces the sum of the frequencies, the difference between the frequencies and the originals.

As the RF is applied to the bases of Q<sub>1</sub> and Q<sub>2</sub> in phase, the push-pull action of the transistors will cause the carrier to cancel out in T<sub>2</sub>.

T<sub>2</sub> is selected to have low impedance to the audio component, effectively short-circuiting it and not allowing it to appear in the output. The generated sidebands will appear at the collectors of Q<sub>1</sub> and Q<sub>2</sub> 180° out of phase. The resultant current causing mutual induction between primary and secondary of T<sub>2</sub> and therefore an output. The sidebands will vary in frequency and amplitude by an amount determined by the modulating frequency and level.

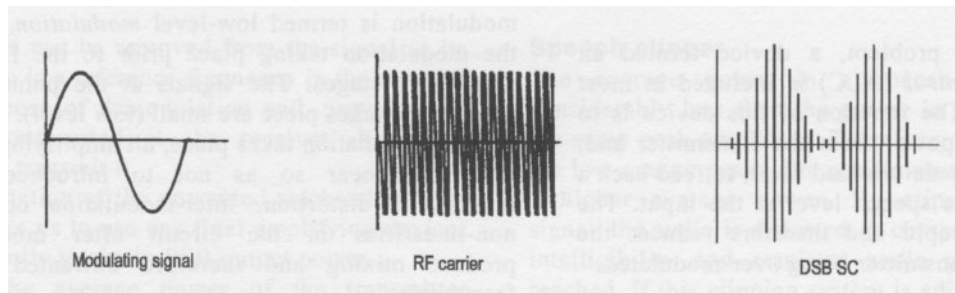

**The output from a balanced modulator as well as the RF carrier and modulating signal.**

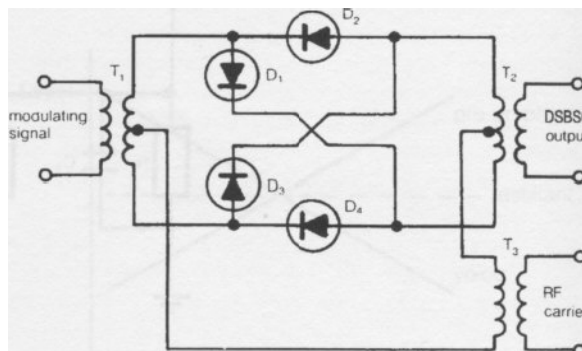

**Balanced ring modulator.**

This device is also a mixer, using the non-linear action of the diodes to produce an output. Frequency selective components are used to obtain the desired output of double sideband suppressed carrier. A balanced ring modulator is shown.

This circuit will be considered with carrier only applied, then carrier and audio applied together. The first half-cycle of input carrier is applied to T<sub>3</sub> negative on the bottom and positive on the top. This voltage is induced into the secondary of T<sub>3</sub>.

The current that will flow due to the voltage in T<sub>3</sub> will split at T<sub>1</sub>. Half the current will flow through T<sub>1</sub> in one direction, while the other half of the current will flow through T<sub>1</sub> in the opposite direction. As these currents will be equal and opposite, their magnetic fields cancel. Diodes D<sub>2</sub> and D<sub>4</sub> conduct. The currents then recombine in T<sub>2</sub> at the centre tap. The currents in T<sub>2</sub> are equal and opposite and their magnetic fields cancel. As the magnetic fields cancel, no output is produced, that is, the carrier is suppressed.

The next half-cycle of carrier will have opposite polarity across T<sub>3</sub>. D<sub>1</sub> and D<sub>3</sub> will conduct. The currents through T<sub>1</sub> and T<sub>2</sub> will be equal and opposite. No output will be produced.

When speech and carrier are applied together, mixing will occur due to the non-linear action of the diodes, and sidebands will be produced.